



The  
**TICKET**  
to  
**HAPPINESS**



Faith Bleasdale



**Faith Bleasdale**

**Faith Bleasdale Untitled Book 4**

# Содержание

THE TICKET TO HAPPINESS	5
Prologue	11
Chapter One	12
Конец ознакомительного фрагмента.	16



# THE TICKET TO HAPPINESS

## FAITH BLEASDALE

avon.

Published by AVON

A Division of HarperCollins*Publishers* Ltd

1 London Bridge Street

London SE1 9GF

[www.harpercollins.co.uk](http://www.harpercollins.co.uk)

First published in Great Britain by HarperCollins*Publishers*

2019

Copyright © Faith Bleasdale 2019

Cover design © HarperCollins*Publishers* 2019

Cover illustrations © [Shutterstock](#)

Faith Bleasdale asserts the moral right to be identified as the author of this work.

A catalogue copy of this book is available from the British Library.

This novel is entirely a work of fiction. The names, characters and incidents portrayed in it are the work of the author's imagination. Any resemblance to actual persons, living or dead, events or localities is entirely coincidental.

All rights reserved under International and Pan-American Copyright Conventions. By payment of the required fees, you have been granted the non-exclusive, non-transferable right to access and read the text of this ebook on screen. No part of this text may be reproduced, transmitted, downloaded, decompiled, reverse engineered, or stored in or introduced into any information storage and retrieval system, in any form or by any means, whether electronic or mechanical, now known or hereinafter invented, without the express written permission of HarperCollins.

Ebook Edition © March 2019; ISBN: 9780008306977

Version: 2019-03-22

*To Sally, wishing you love and happiness in your new adventure!*

Table of Contents

[Cover](#)

[Title Page](#)

[Copyright](#)

[Dedication](#)

[The Singer Family Tree](#)

[Prologue](#)

[Chapter One](#)

[Chapter Two](#)

[Chapter Three](#)

[Chapter Four](#)

[Chapter Five](#)

[Chapter Six](#)

[Chapter Seven](#)

[Chapter Eight](#)

[Chapter Nine](#)

[Chapter Ten](#)

[Chapter Eleven](#)

[Chapter Twelve](#)

[Chapter Thirteen](#)

[Chapter Fourteen](#)

[Chapter Fifteen](#)

[Chapter Sixteen](#)

[Chapter Seventeen](#)

[Chapter Eighteen](#)

[Chapter Nineteen](#)

[Chapter Twenty](#)

[Chapter Twenty-one](#)

[Chapter Twenty-two](#)

[Chapter Twenty-three](#)

[Chapter Twenty-four](#)

[Chapter Twenty-five](#)

[Chapter Twenty-six](#)

[Chapter Twenty-seven](#)

[Chapter Twenty-eight](#)

[Chapter Twenty-nine](#)

[Chapter Thirty](#)

[Chapter Thirty-one](#)

[Chapter Thirty-two](#)

[Chapter Thirty-three](#)

[Epilogue](#)

[Acknowledgements](#)

[Keep Reading ...](#)

[About the Author](#)

[About the Publisher](#)

# The Singer Family Tree

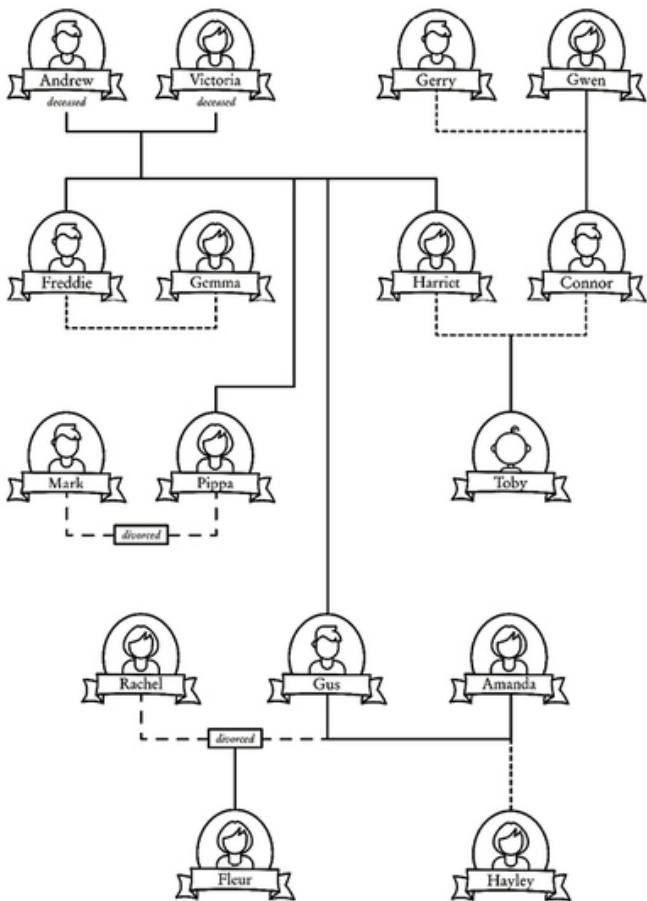



## Prologue

The Californian sun streamed through the window, highlighting the house she was looking at on the computer screen. Meadowbrook Manor, a boutique hotel in Somerset, the UK. The house drew her in as she peered at the big windows, the impressive front door, the inviting interior as shown in the photos that had been taken of the inside. She could almost see, almost *feel* herself there.

She noticed a tear sliding down her cheek, which surprised her, as she hadn't realised she'd been crying. She angrily brushed it away. There had been so much, too much that had brought her to this point, and as she stared at the hotel she begged it to give her the answer she needed. Although it felt hopeless, she was desperate to understand. After a while, she felt her heart start to warm. She knew it was crazy, but it really felt as if Meadowbrook was talking to her, calling her.

Before she had time to change her mind she pulled up another website, this time for flights, and with a few clicks she'd booked herself a ticket. She hoped, no she *knew*, in her heart that it was the right thing to do. That ticket was going to take her to just where she needed to be.

# Chapter One

Pippa could feel a smile inching its way across her face before she opened her eyes. Today was going to be a good day. She sprang out of bed with childlike enthusiasm, opening the curtains in her small bedroom that overlooked Meadowbrook's magnificent gardens. Meadowbrook Manor, a grand Georgian house, had been home to her and her three siblings for their entire childhood. They'd lived with just their father, Andrew Singer, throughout most of this time, as their mother had passed away when Pippa was only four years old.

And since Andrew's death, Meadowbrook had become much more than just a family home to the Singer siblings. They'd turned it into a boutique five-star hotel.

Pippa looked out at the sweeping gardens. Even in winter, they were perfectly maintained and deserving of the reputation that made them an attraction. They had been her father's pride and joy, so they remained important to Pippa and her three siblings, as did the animal sanctuary that lay just beyond – another great love of their father's before he passed away.

She took a moment to enjoy the view that stretched out over the Mendip countryside. It was a rare interlude, as Pippa was now busier than ever. Opening and running the hotel was pretty much the only job she'd ever had, but she was lucky that she loved doing it. She was a people person, so managing a hotel,

charming the guests, making sure their every whim was catered for, played to her strengths. Although her sister and two brothers were involved in the hotel in their own way, it was still largely her baby. The only baby she had.

She brushed this negative thought away. She often thought about how just a few short years ago she'd been married to Mark, a controlling man who'd turned out to be ruthless and uncaring. But she didn't see it until it was almost too late, as one often did in such relationships, and since then she'd been largely single.

Before her divorce, Pippa had always thought she'd have children and become a mum, rather than run a hotel, but she had learnt the hard way that life didn't always work out the way you thought it would. And she was better off now. Surrounded by her siblings and their partners, she did sometimes feel a little sad about being single, but she was only thirty-two, after all – it wasn't as if she was an old maid just yet ... although she felt like it at times. Pippa once again pushed those negative thoughts away. Lately, she'd been letting negativity creep into her head, but not today.

She hopped around the room with an energy that seemed on endless supply since the hotel opened. Though the first few months had been anxious ones, Pippa had barely come up for air, but now the hotel had found its rhythm. In fact, Pippa was preparing a party to celebrate its one-year anniversary.

Like with many things at Meadowbrook, the anniversary was slightly unconventional in that they were celebrating over

a month early. The official opening of the hotel had been held on Valentine's Day last year, and her brother Gus's wedding to Meadowbrook garden designer, Amanda, had marked that occasion. But as they had bookings this year for those in search of romance, they were holding the party early during the first week of January. Not only was it quiet, but everyone involved with Meadowbrook would also welcome a party to fend off the post-Christmas and New Year blues. No one she knew did dry January, after all. Her brother Freddie said if you were going to pick a month to give up drinking, why pick the coldest, longest and most depressing? She had to admit he had a point.

Although they all had different strengths and often bickered, the Singer siblings all agreed that Pippa should take the lead on the hotel as manager and they supported her in different ways. She often wondered what her father would think of her now. Andrew Singer was driven, complicated, successful and loving, and she missed him every single day.

Harriet Singer was the business brain behind Meadowbrook, the hotel and the animal sanctuary, as well as their father's various investments and complicated estate. Gus, the second oldest, took care of the gardens; Amanda and he ran a gardening company that was hugely in demand. He also painted and ran increasingly popular painting workshops at the hotel. Freddie, her third sibling, was sort of her co-manager but he ran the bar, his particular area of interest, and took care of all the marketing and social media. Somehow, they'd figured out how to do this

together, without too much fighting. They'd almost made it to a year with no casualties at the very least, and Meadowbrook was open for business.

After showering, Pippa dried herself and pulled on a pair of jeans and a new cream jumper. Having kept this weekend free of guests for the anniversary party, the hotel felt eerily quiet, and Pippa wasn't used to being here on her own. But this morning, for a little while at least, it was just her. She smiled as she made her way to the kitchen and poured a large mug of coffee. She leant against the counter, thankful for a moment's peace and quiet. Yes, today was going to be a good day ...

# Конец ознакомительного фрагмента.

Текст предоставлен ООО «ЛитРес».

Прочитайте эту книгу целиком, [купив полную легальную версию](#) на ЛитРес.

Безопасно оплатить книгу можно банковской картой Visa, MasterCard, Maestro, со счета мобильного телефона, с платежного терминала, в салоне МТС или Связной, через PayPal, WebMoney, Яндекс.Деньги, QIWI Кошелек, бонусными картами или другим удобным Вам способом.